

2B TYPE LADDER

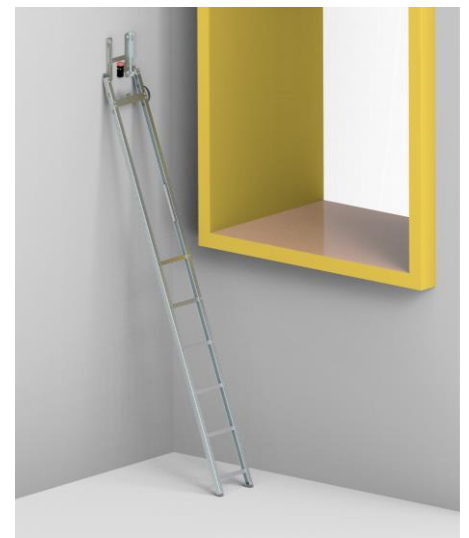

NO FLOOR DRILLING NEEDED!
 ¡SIN NECESIDAD DE FIJACION AL SUELO!
IDEAL FOR WATERPROOFED PITS
 IDEAL PARA FOSOS IMPERMEABILIZADOS



Se trata de un producto diseñado para acomodarse a espacios reducidos. Está fabricada en acero galvanizado y aluminio, y está especialmente pensada para fosos impermeabilizados

Se ha diseñado para satisfacer los requisitos de la EN81-20 y EN81-21 de manera que pueda adaptarse dimensionalmente a la mayoría de las instalaciones.

This is a product designed to provide a solution to narrow spaces. It is manufactured with galvanized steel and aluminium, and it is specially designed be installed on waterproofed pits.

It has been designed to meet the requirements of the EN81-20 and EN81-21, and it can adapt dimensionally to most of the applications in the field.

**COMPACIDAD /
 COMPACTNESS**

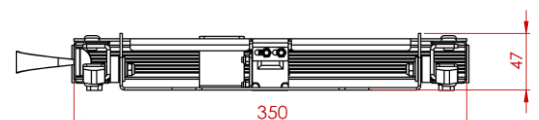

2B TYPE LADDER

Cómo hacer un pedido / How to order:

Mod.
B200

Mod.	L (mm)	Nº Steps	Altura Foso / Pit Height (mm)	Safety Switch
B050	1845	3	500-680	1NC / 1NO: EN 81-20 COMPLIANT
B100	2135	4	681-960	
B200	2425	5	961-1251	
B300	2815	6	1252-1618	
B400	3105	7	1619-1900	

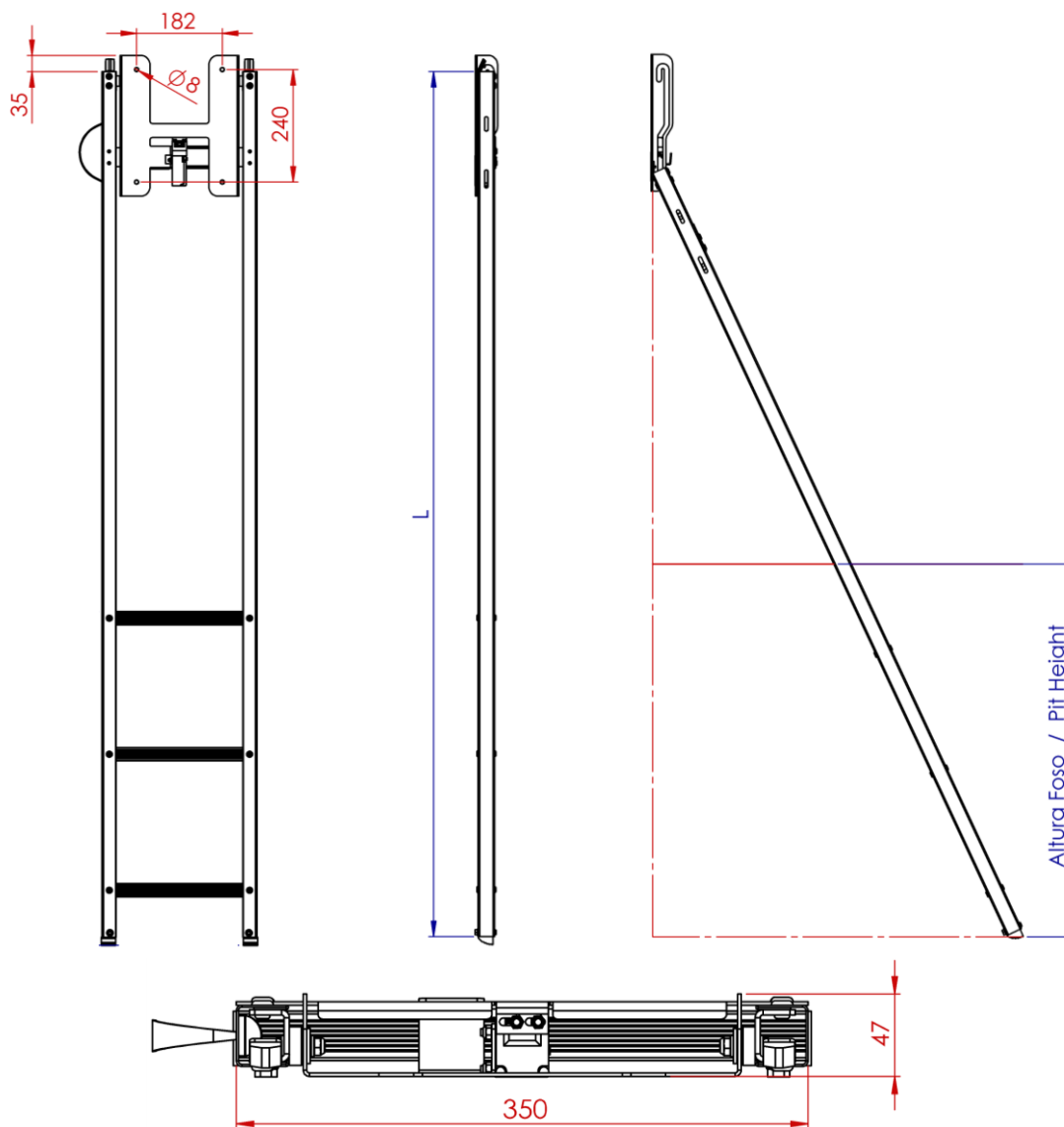

Nota/Note: La información proporcionada en este catálogo es no vinculante, y no se debería usar como sustituto de consultas individuales detalladas.
This catalogue provides non-binding general information, and should not be used as a substitute for a detailed individual consultation.